



## GROOVED TWO-SIDED GRILLS

Models CG10I, CG14, CG14I, CG14IGT, CG28I & CG28IGT

### Features/Benefits:

- ★ Star's Grooved "Panini" Grill enhances the looks of your menu by adding sear marks to your sandwiches, chicken breasts, hamburgers or other menu items.
- ★ Available in three sizes 10", 14" and 28" width platen to fit volume foodservice operations.
- ★ Heavy-duty 10", 14" and 28" cast iron or aluminum platens provide long life and superior performance keeping up with your menu requirements.
- ★ A heavy-duty counter balance hinge system provides you safe and effortless operation of the top platen.
- ★ Spacious grilling height accommodates product up to three inches with 3-4 pounds of pressure for proper cooking between platens.
- ★ Top and bottom grill cooks your menu items in half the time, sealing in the flavor.
- ★ The bottom platen has a patented splash guard to help keep products and grease in their place.
- ★ Ergonomically designed control panel provides easy access to controls and grease drawer.
- ★ Heavy gauge water resistant and flexible plastic conduit protects electrical connections.
- ★ Thermostat is rated from 175°F (79°C) to 550°F (302°C) and provides accurate sensing of temperature.
- ★ Grease trough located in front of bottom platen allows easy clean up.
- ★ Extended painted aluminum handle provides heavy-duty, safe operation of the top platen.
- ★ Removable, large capacity grease drawer in the front of unit for easy clean up.

### Application:

Star's "Panini" Grills can prepare sandwiches, chicken breasts, hamburgers and a variety of other menu items in your restaurant, cafe, concession stand, bar, or wherever you need high performance cooking. Grills are compact and portable providing flexibility in your operation.

### Quality Construction:

Star's Two-Sided "Panini" Grills are constructed of 18 gauge stainless steel. Units available with cast iron or aluminum grooved platens. Star's counter balance hinge mechanism allows up to 3" of grilling height with 3-4 pounds of pressure for cooking of products between platens. Metal tubular elements are standard. The 6 foot lead-in cord is resistant to water and oil and metallic braiding protect wiring. Furnished with a 6' cord and standard NEMA plug.

### Warranty:

Two-Sided Grills are covered by Star's one year parts and labor warranty.

Patent No. 6,257,126



Model CG10I



Model CG14





## GROOVED TWO-SIDED GRILLS

Models CG10I, CG14, CG14I, CG14IGT, CG28I & CG28IGT

Two-Sided Grooved Grills

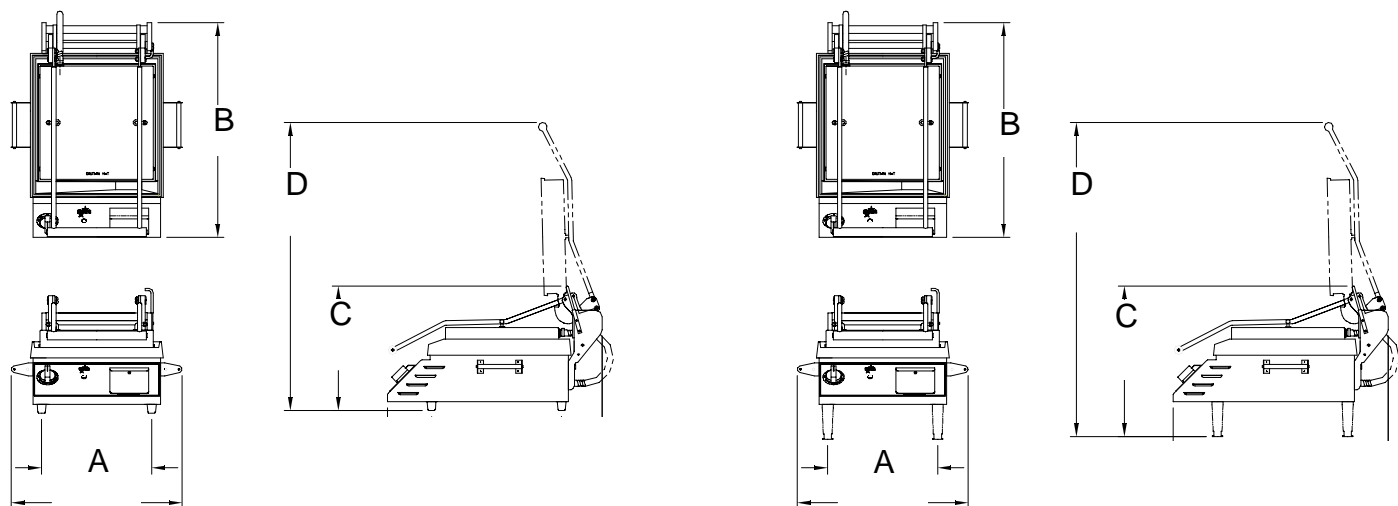

### Model and Specifications

Model No.	Grid Surface	(A) Width (cm)	(B) Depth (cm)	Height		Voltage	Wattage	Amps	NEMA (kg)	Approximate Weight	
				(C) Closed (cm)	(D) Open (cm)					Shipping (kg)	Installed
CG10I	Iron	16-1/8" (40.9)	21-1/8" (53.7)	13-1/4" (33.7)	29-1/2" (74.9)	120V 208/240V	1800 1350/1800	15 6.5/7.5	5-15P 6-15P	67 lbs. (30.4)	57 lbs. (28.1)
CG14	Alum.	19-5/8" (49.8)	24-3/4" (62.9)	13-1/2" (34.3)	32-3/4" (83.2)	120V 208/240V	1800 1350/1800	15 6.5/7.5	5-15P 6-15P	67 lbs. (29.5)	55lbs. (24.9)
CG14I	Alum.	19-5/8" (49.8)	24-3/4" (62.9)	13-1/2" (34.3)	36-1/2" (92.7)	120V 208/240V	1800 1350/1800	15 6.5/7.5	5-15P 6-15P	67 lbs. (29.5)	55lbs. (24.9)
CG14IGT Grooved Top Only	Iron	19-5/8" (49.8)	24-3/4" (62.9)	17" (43.2)	36-1/2" (92.7)	208V 240V	2700 3600	13 15	6-20P	101 lbs. (44.0)	87 lbs. (39.4)
CG28I	Iron	34-1/4" (86.9)	24-3/4" (62.9)	17" (43.2)	36" (91.4)	208V 240V	5400 7200	26 30	L6-30P	206 lbs. (93.4)	171 lbs. (77.5)
CG28IGT Grooved Top Only	Iron	34-1/4" (86.9)	24-3/4" (62.9)	17" (43.2)	36" (91.4)	208V 240V	5400 7200	26 30	L6-30P	206 lbs. (93.4)	171 lbs. (77.5)

### Typical Specifications

Two-Sided Grill is constructed with an 18 gauge stainless steel body. Cast iron or aluminum grooved platens are standard. A counter balance mechanism provides easy operation, the top platen. Grilling height between platens is up to 3" with counter balance system providing 3-4 pounds of pressure to the cooking product placed on bottom platen. Metal sheathed tubular elements shall be provided as standard. Adjustable non-skid feet shall be standard. Unit shall be provided with pilot light, six foot power cord with Nema rated plug (see specifications above). Unit shall carry approval of UL, UL Sanitation or UL Canada Standards. Printed in the U.S.A.

Star Manufacturing International Inc. - 10 Sunnen Drive - P.O. Box 430129 - St. Louis, MO 63143-3800

Phone: (800) 264-7827 - FAX: (800) 264-6666 - www.star-mfg.com