



TABLE MOUNTED

STAINLESS STEEL ADJUSTABLE DOUBLE OVERSHELF WITH 6" OFFSET

Item #: _____ Qty #: _____

Model #: _____

Project #: _____



Cantilevered
Edge



CDS shelving includes
adjustable hex
Leg Gusset Installation

L	18" Wide	Wt
36"	CDS-18-36	39 lbs.
48"	CDS-18-48	55 lbs.
60"	CDS-18-60	71 lbs.
72"	CDS-18-72	87 lbs.
84"	CDS-18-84	103 lbs.
96"	CDS-18-96*	119 lbs.
108"	CDS-18-108*	135 lbs.
120"	CDS-18-120*	155 lbs.
132"	CDS-18-132*	175 lbs.
144"	CDS-18-144*	195 lbs.

* 96" or Longer Include 3 Sets of Legs

FEATURES:

18" wide fully adjustable shelving.
Includes four 1 5/8" Stainless Steel Heavy Duty Posts.
Gussets feature Hex Leg Gusset Lock & Set Screw.

CONSTRUCTION:

All TIG welded.
Exposed surfaces polished to a satin finish.

MATERIAL:

All Shelves are 18 gauge type "430" stainless steel.
Holes are required in Table Top.

MODIFICATIONS:

Use **TA-47** for special mounting hardware to easily add to existing tables. (for special modifications, consult factory)
Use **TA-99** for 16 Gauge, 304 Stainless Steel Upgrade.



Customer Service Available To Assist You **1-800-645-3166** 8:30 am - 7:00 pm E.S.T.

For Orders & Customer Service:

Email: customer@advancetabco.com or Fax: 631-242-6900

For Smart Fabrication™ Quotes:

Email: smartfab@advancetabco.com or Fax: 631-586-2933

DETAILS and SPECIFICATIONS

TOL \pm .500"

ALL DIMENSIONS ARE TYPICAL

CDS SERIES: DOUBLE DECK TABLE MOUNTED WITH 6" OFFSET

Specify location. Front, Center or Rear. Rear 1 1/2" Turn-Up is Available. Specify if Required.

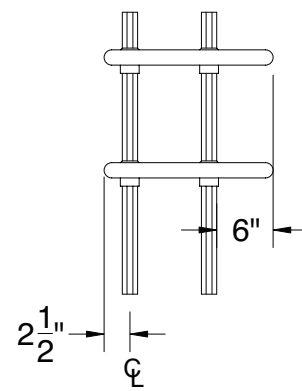
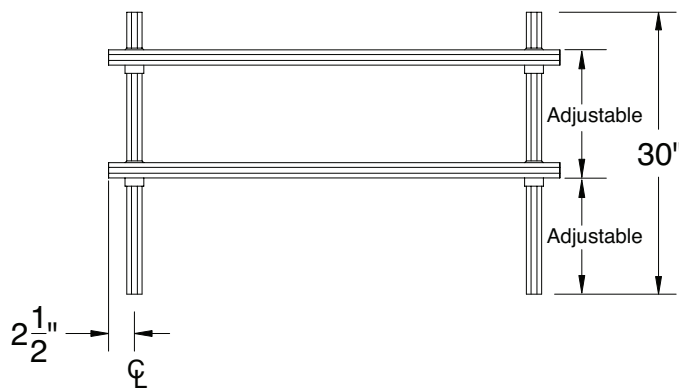
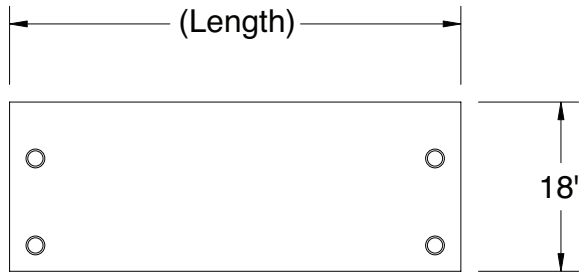

Rubber Expander
Table Mounting
Hardware Included

